



fractus

Optimised Antennas
for Wireless Devices

User Manual

Fractus Media+™

Ultra Wideband

Chip Antenna

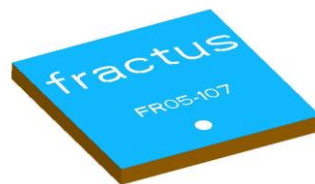

**Antenna Part Number:
FR05-S1-P-0-107**





TABLE OF CONTENTS

NOTES	2
ANTENNA DESCRIPTION	3
QUICK REFERENCE GUIDE	3
ELECTRICAL PERFORMANCE	4
FRACTUS EVALUATION BOARD	4
CAPABILITIES AND MEASUREMENT SYSTEMS	6
MECHANICAL CHARACTERISTICS	7
DIMENSIONS, TOLERANCES & MATERIALS	7
SPECIFICATIONS FOR INK	8
ASSEMBLY PROCESS	9
ANTENNA FOOTPRINT	11
PACKAGING	12

Fractus is an **ISO 9001:2008** certified company
All our antennas are lead-free and **RoHS** compliant

NOTES

Any update on new patents linked to this product will appear in <http://www.fractus.com/index.php/fractus/patents>

All information contained within this document is property of Fractus and is subject to change without prior notice. Information is provided "as is" and without warranties. It is prohibited to copy or reproduce this information without prior approval.



ANTENNA DESCRIPTION

Fractus® Media+ UWB chip antenna is a high-performance, cost-effective antenna designed to meet the requirements of reference designers, OEMs and ODMs considering the Multiband OFDM alliance (MBOA) recommendations for Ultra Wideband devices.

The electrical and mechanical characteristics of this small SMD monopole chip antenna ensures design flexibility and optimal performance in devices such as, but not limited to:

- Wireless USB (W-USB) dongles
- W-USB enabled devices: digital cameras and video recorders, PC Peripherals, beamers, PDAs, Mobile Phones, Compact Flash and Secure Digital Cards

PRODUCT BENEFITS

- High efficiency
- Cost-effective
- Small size

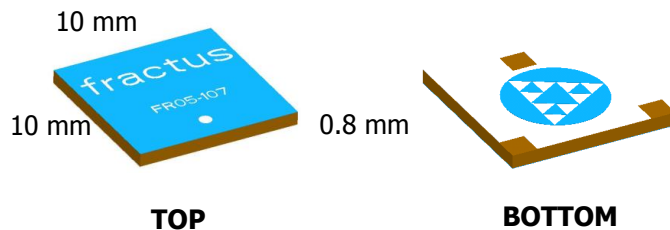

QUICK REFERENCE GUIDE

Technical Features	
Frequency Range	3.1 – 5 GHz
Average Efficiency	84%
Peak Gain	3.5 dB
Radiation Pattern	Omnidirectional
Flatness	2 dB gain variation
VSWR	<2:1
Weight	0.2 g
Temperature	-40 to 85°C
Impedance	50 Ω
Dimensions (L x W x H)	10 mm x 10 mm x 0.8 mm

Please contact at info@fractus.com if you require additional information on antenna integration or optimisation on your PCB.

FRACTUS S.A.
www.fractus.com
Tel: +34 935442690
Fax: +34 935442691

Table 1 -Technical Features. Measures from the evaluation board (36.5 mm x 20 mm x 0.8 mm PCB)



ELECTRICAL PERFORMANCE

FRACTUS EVALUATION BOARD

The configuration used in testing the Media+ UWB chip antenna is displayed in Figure 1.

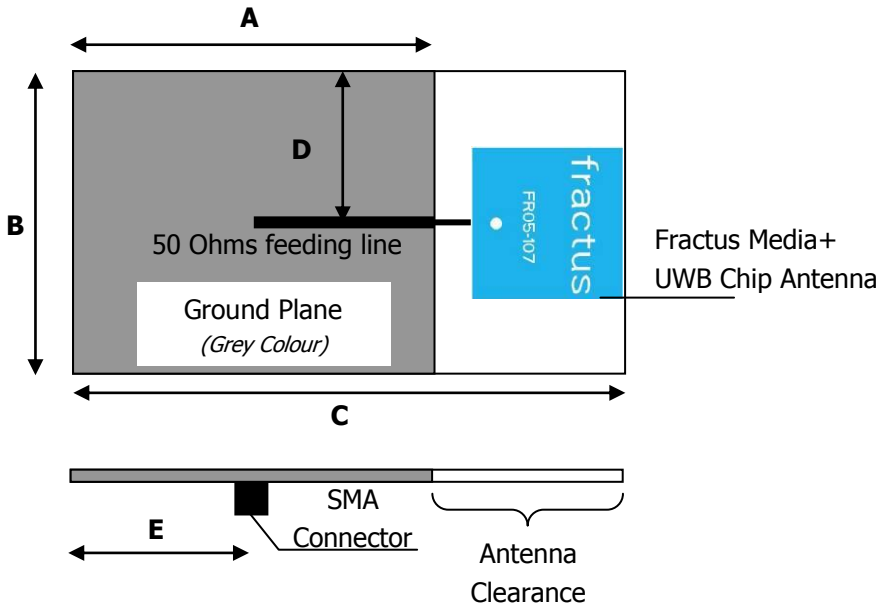

Measure	mm
A	23.9
B	20
C	36.5
D	10
E	12

Tolerance: $\pm 0.2\text{mm}$

Material: The evaluation board is built on FR4 substrate with 0.8 mm of thickness.

Figure 1 – Fractus Media+ UWB chip Antenna

VSWR and Efficiency

VSWR (Voltage Standing Wave Ratio) and Efficiency versus Frequency (GHz)

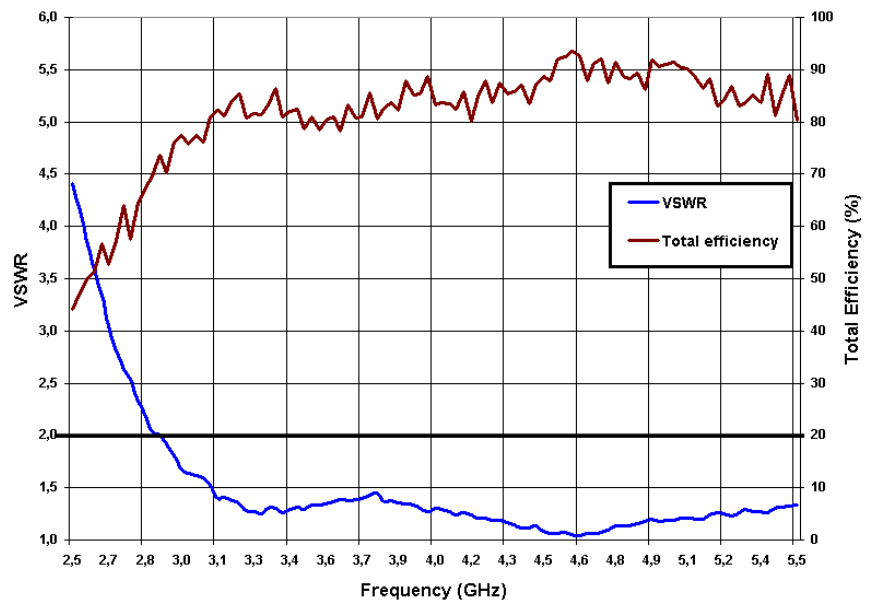



RADIATION PATTERN, GAIN AND EFFICIENCY

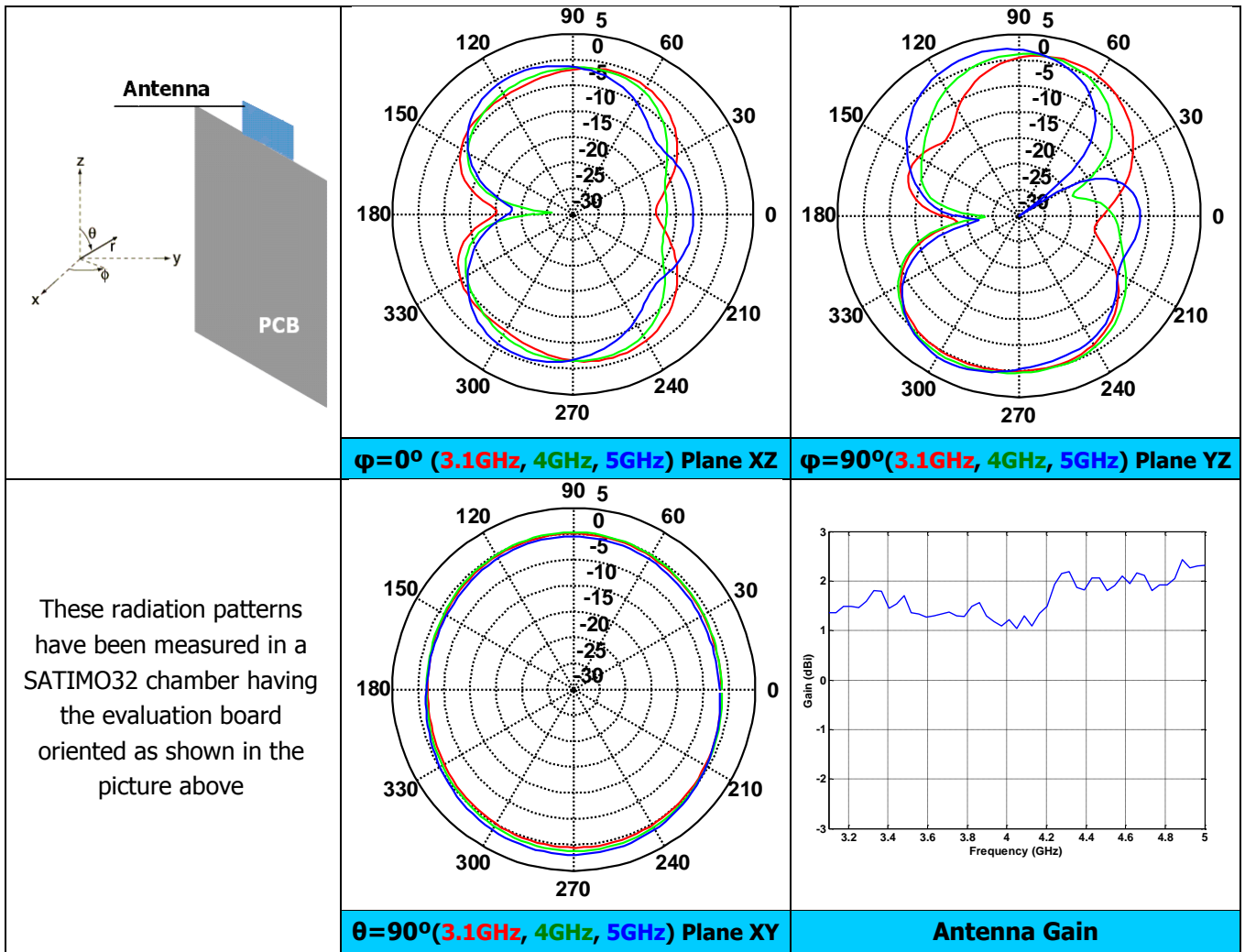

Gain	Peak Gain	3.5 dB
	Average Gain across the band	2.6 dB
	Gain Flatness (horizontal plane)	< 2 dB
Efficiency	Peak Efficiency	92%
	Average Efficiency across the band	84%
	Efficiency Range across the band	77% - 92%

Table 2 – Antenna Gain and Efficiency within the 3.1 to 5 GHz bandwidth. Measures made in the evaluation board and in the Satimo STARGATE 32.



CAPABILITIES AND MEASUREMENT SYSTEMS

Fractus specialises in designing and manufacturing optimised antennas for wireless applications and providing our clients with RF expertise. We offer turn-key antenna products and antenna integration support to minimise your time requirement and maximize your return on investment during your product development efforts. We also provide our clients with the opportunity to leverage our in-house testing and measurement facilities to obtain accurate results quickly and efficiently.



Agilent E5071B

VSWR
&
S Parameters

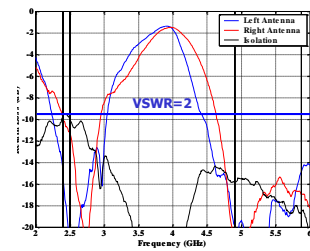

SATIMO's STARGATE 32

Radiation
Pattern
&
Efficiency

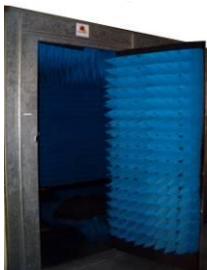
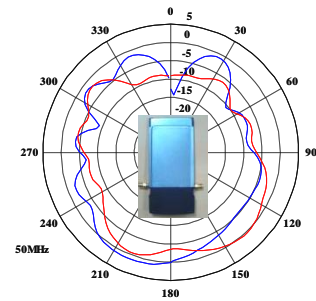

Anechoic and semi-anechoic chambers and full equipped in-house lab



MECHANICAL CHARACTERISTICS

DIMENSIONS, TOLERANCES & MATERIALS

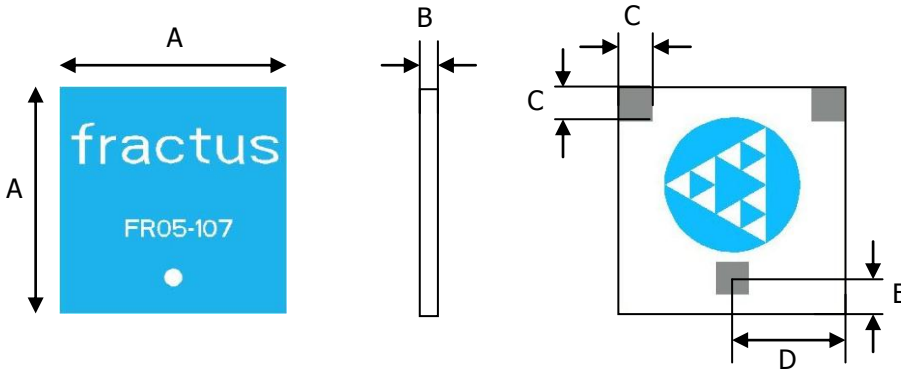

Note: all the antenna pads (feed point and mounting pads) have the same dimensions.

Figure 2 – Antenna Dimensions and Tolerances

Measure	mm	Measure	mm
A	10 ± 0.2	D	5 ± 0.2
B	0.8 ± 0.2	E	1.55 ± 0.1
C	1.5 ± 0.1		

The white circle located on the front side of the antenna, provides you with a visual cue to mount the antenna. It is located physically above the feed point of the antenna and has been included to decrease possible manufacturing error.

Fractus Media+ UWB chip antenna is compliant with the directive **2002/95/EC** on the restriction of the use of hazardous substances (**RoHS**). Should you require a green certificate (RoHS report), please contact your sales representative at info@fractus.com.



SPECIFICATIONS FOR INK

Blue (pantone 312)	<ul style="list-style-type: none">• 50% Blue CARAPACE EMP 110-3245• 50% White ink CARAPACE
White	<ul style="list-style-type: none">• White ink CARAPACE

Next figure shows the correct colours of the antenna:

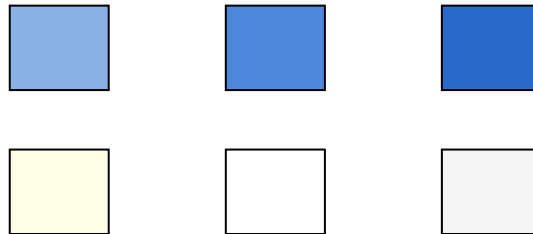

Acceptable colour range



ASSEMBLY PROCESS

Figure 3 shows the back and front view of the Fractus Media+ UWB chip antenna and indicates the location of the feeding point and the mounting pad:

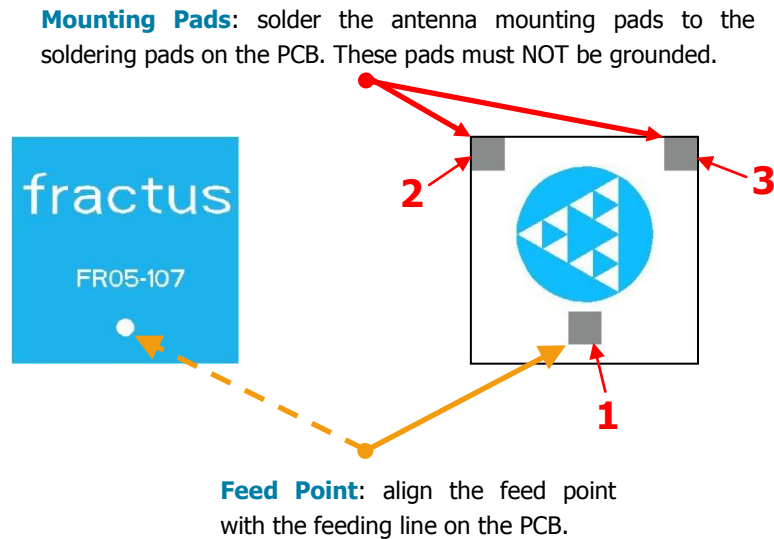

Figure 3 –Views of the Fractus Media+ UWB chip antenna

As a surface mount device (SMD), this antenna is compatible with industry standard soldering processes. The basic assembly procedure for this antenna is as follows:

1. Apply a solder paste on the pads of the PCB. Place the antenna on the board.
2. Perform a reflow process according to the temperature profile detailed in table 3 figure 5 of page 9.
3. After soldering the antenna to the circuit board, perform a cleaning process to remove any residual flux. Fractus recommends conducting a visual inspection after the cleaning process to verify that all reflux has been removed.

The drawing below shows the soldering details obtained after a correct assembly process:

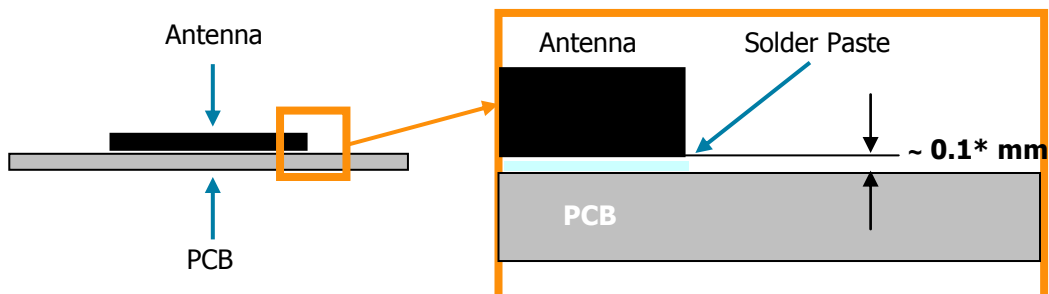

Figure 4 - Soldering Details

NOTE: Solder paste thickness after the assembly process will depend on the thickness of the soldering stencil mask. A stencil thickness equal or larger than **127 microns (5 mils)** is required.



Fractus Media+ UWB chip antenna can be assembled following either Sn-Pb or Pb-free assembly processes. According to the Standard **IPC/JEDEC J-STD-020C**, the temperature profile suggested is as follows:

Phase	Profile features	Sn-Pb Assembly	Pb-Free Assembly (SnAgCu)
RAMP-UP	Avg. Ramp-up Rate (T_{Smax} to T_p)	3 °C / second (max.)	3 °C / second (max.)
PREHEAT	<ul style="list-style-type: none"> - Temperature Min (T_{Smin}) - Temperature Max (T_{Smax}) - Time (t_{Smin} to t_{Smax}) 	100 °C 150 °C 60-120 seconds	150°C 200°C 60-180 seconds
REFLOW	<ul style="list-style-type: none"> - Temperature (T_L) - Total Time above T_L (t_L) 	183 °C 60-150 seconds	217 °C 60-150 seconds
PEAK	<ul style="list-style-type: none"> - Temperature (T_p) - Time (t_p) 	235 °C 10-30 seconds	260 °C 20-40 second
RAMP-DOWN	Rate	6 °C / second max.	6 °C/second max.
Time from 25 °C to Peak Temperature		6 minutes max.	8 minutes max.

Table 3 – Recommended soldering temperatures

Next graphic shows temperature profile (grey zone) for the antenna assembly process in reflow ovens.

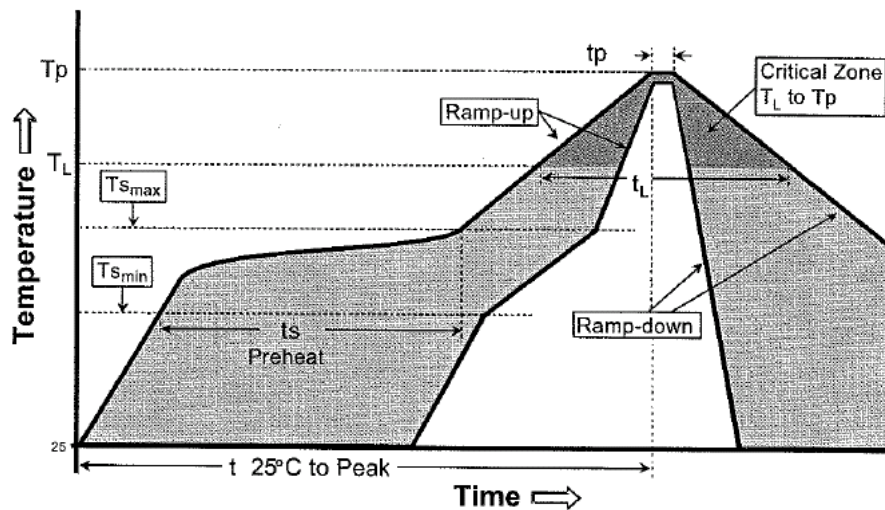
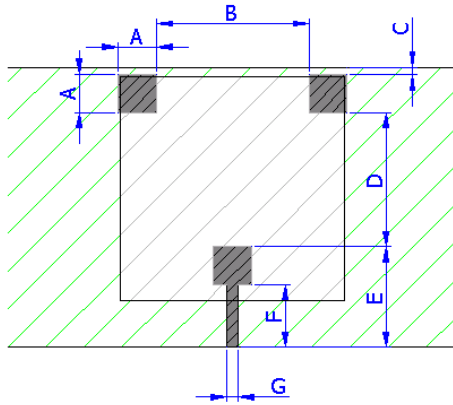

Figure 5 – Temperature profile



ANTENNA FOOTPRINT

This antenna footprint applies for the reference evaluation board described in page 4 of this User Manual.



Note: all the soldering pads (feed point and mounting pads) on the antenna layout have the same dimensions.

Measure	mm
A	1.9
B	6.8
C	0.3
D	6
E	4.5
F	2.8
G	0.5

Tolerance: $\pm 0.2\text{mm}$



-  Zone occupied by the antenna
-  Soldering pads and feed point
-  Clearance (PCB area without ground-plane)

Figure 6 – Antenna Footprint Details

Other PCB form factors and configurations may require a different feeding configuration, feeding line dimensions and clearance areas. If you require support for the integration of the antenna in your industrial design, we would be pleased to assist you with this design process.

Please, contact your local sales representative at info@fractus.com to receive additional information on recommended configurations for different devices.

FRACTUS, S.A.
www.fractus.com
 Tel: +34 935442690
 Fax: +34 935442691



PACKAGING

The Fractus Media+ UWB Chip antenna is available in tape and reel packaging.

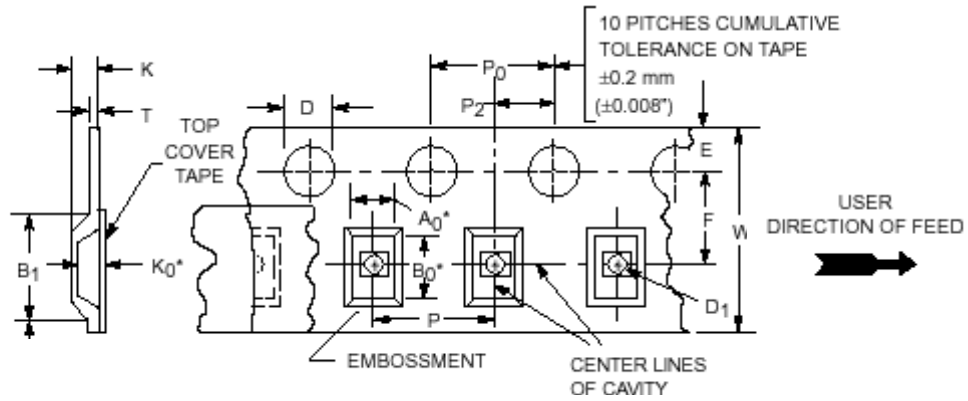

Measure	mm	Measure	mm
TAPE WIDTH	15.50	Wmax	16.00
A0	10.50	E	1.60
B0	10.50	F	7.50
K0	1.35	K	1.65
B1	10.60	P	12.0
D	1.50	P0	4.0
D1	1.50 min	P2	2.0

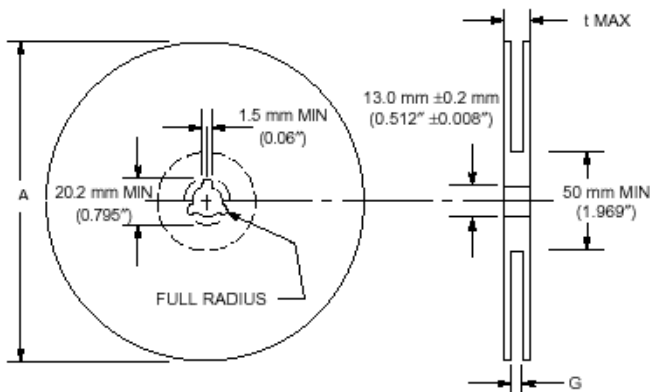
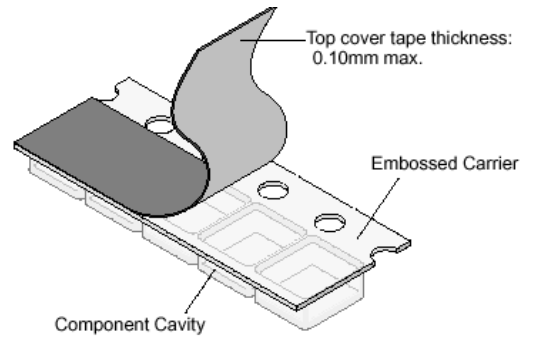

Measure	mm
A max	360
G min	16.4
T max	22.4 max

Tolerance: $\pm 0.2\text{mm}$

Reel Capacity: 2500 antennas.

Figure 7 – Reel Dimensions and Capacity